

Federation State Unitary Enterprise
Production Amalgamation
"Novosibirsk Instrument-Making Plant"



SIGHT «RAKURS-A»

SERVICE MANUAL
AL3.812.251 RE

Due to continuous product improvements, specifications are subject to change without notice.

Present manual describes design, operation, performance features, and service instructions essential for correct use of technical features of the sight.

1 PURPOSE

The sight «Rakurs-A» (hereinafter referred to as the sight) is intended for aiming shooting on the range of direct shoot from the smooth-bore and rifled hunting weapon with the side slot.

The illuminated reticle allows to aim during the twilight when the target is seen.

The sight operates from ambient temperature range from -40 to +40 °C and relative humidity up to 98% at temperature +25 °C.

2 PERFORMANCE FEATURES

Magnification, x	1
Angular field of view in the objects area	13°
Eye relief, mm	100
Exit pupil diameter, mm	20
Overall dimensions, mm:	180×65×110
Weight ,kg, max	0.5

3 DELIVERY SET

The sight «Rakurs-A»	1
Carrying bag	1
Service manual	1

4 ADJUSTMENT ON THE WEAPON AND ZEROING

4.1 The sight consists of the following main parts:

- casing 1 (Fig. A.1) with built-in objective, eyepiece, turning prism with aiming reticle, zeroing windage and elevation mechanisms.

- bracket 2 with clutch attached, intended for adjustment the sight on the weapon. The clutch consists of the bracket 3, screw 5, catch 6, handle 7, handle 8, washer 4.

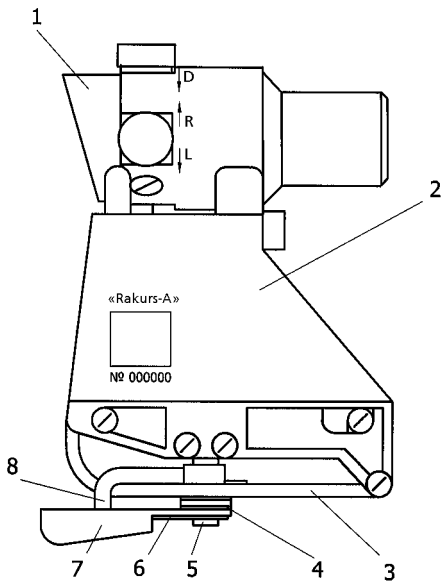

- 1 – casing; 2 – bracket;
 3 – bracket; 4 – washer;
 5 – screw; 6 – catch;
 7 – handle; 8 – handle

Figure A.1 – **The sight «Rakurs-A».**
Side view

4.2 To illuminate the aiming reticle in the twilight the light source 3 (Fig. A.2) is used. It consists of the light element, which operation is based on the effect of emitting the visible radiation by phosphor.

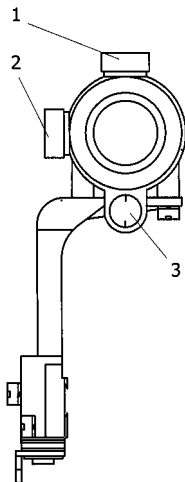

1, 2 – cap; 3 – light source

Figure A.2 – **The sight «Rakurs-A».**
The rear view

4.3 The elevation and windage zeroing mechanisms are closed with thread caps 1 and 2 and has a discrete move with a fixation through 0-00,25.

4.4 The sight is adjusted on the weapon, which has a special side seat of the dovetail type. When adjusting, it is necessary to connect the slot of the sight clutch with the seat of dovetail mounting by turning the handle 7 (Fig. A.1) forward up to the complete fixation of a lug to a sight mounting.

The sight must be fastened well on the mounting of a weapon.

4.5 Do the following to adjust the clutch of the sight to the side mounting of a weapon:

- turn the catch 6, freeing it from the head of a screw 5 and remove it;
- shift the handle 7 to that number of teeth, which will provide the secure fastening, excluding swaying on the mounting of a weapon;
- put the clutch 6 to its place.

4.6 Do the following for zeroing the sight on a weapon:

- adjust the sight on the side slot of a weapon and adjust the clutch of a sight to the slot of a weapon according to 4.5 if necessary;

- adjust on the sighting strip 1, if the weapon is rifled;
- aim the weapon by mechanical sight at the aim point on the distance of 100 m for rifled weapon and for 50 m for smooth-bore;
- check the coincidence of the top of the aiming point reticle with the same aim point as for the mechanical sight;
- if these points do not coincide, combine the peak of the reticle aiming sign with the aim point as for the mechanical sight by turning the caps 1 and 2 (Fig. A.2).
- screw the caps 1 and 2.

5 OPERATION

When firing, coincide the top of the aiming fence of the sight reticle with the aiming point. To avoid the overtoppling of the weapon, hold the lines to the right and left side of the aiming fence horizontally.

6 RULES OF STORAGE

Wipe outer optical surfaces with soft clean fabrics, oil spots and dust remove with a cotton, wet in alcohol.

Keep optical details from scratches during storage and operation.

7 SAFETY

Check periodically and adjust the mounting of the sight on a weapon (if needed) according to the point 4.5.

8 ACCEPTANCE CERTIFICATE

The sight «Rakurs-A», works number _____, meets the requirements of technical documentation and is accepted ready for operation.

Date of manufacturing _____

Signatures _____

Federation State Unitary Enterprise
Production Amalgamation
“Novosibirsk Instrument-Making Plant”,
179/2, D.Kovalchuk,
Novosibirsk, 630049
Russia